

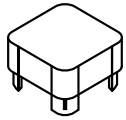

DIVIDER POST PARTS KIT

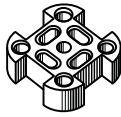

Top Cap x 1



Mounting Plate x 1



1 1/4" Screw x 4



Washer x 1



Locknut x 1



1" Screw x 4

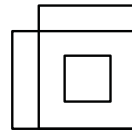

Template x 1

- a. Divider post x 1
- b. Cover strip x 3
- c. Threaded Rod x 1

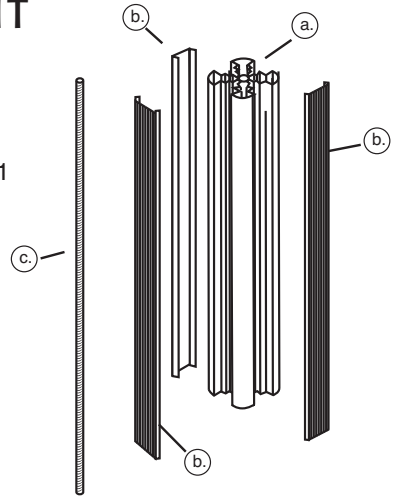

PANEL PARTS KIT

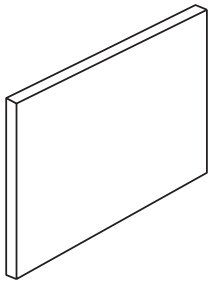

Regular Panel x 1



Filler Panel x 1



3/4" Screw x 8

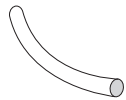

Neoprene Strip x 2
(with glazed panel kit only)

TRANSACTION TOP PARTS KIT

(Not recommended for use on 24" posts)

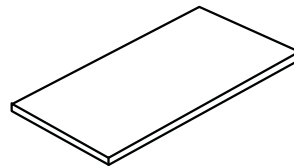

Regular **OR**
Corner Panel x 1

OR

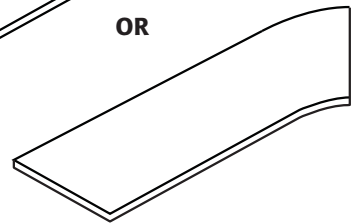

3/4" Screw x 8

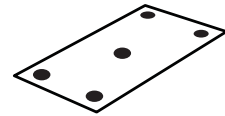

Flat Bracket x 2



STEP 1. ATTACH MOUNTING PLATE

- 1.1 Fold sides of template downward and position template tight against work surface corner.
- 1.2 Expose double sided tape and position mounting plate inside the template opening.
- 1.3 Remove the template and install the short 1" screw into one of the inside holes. Do not tighten.
DO NOT INSTALL ANY OTHER SCREWS
- 1.4 Install the mounting plate that is to be fixed at the other end of the work surface by following steps 1.1 to 1.3 above.

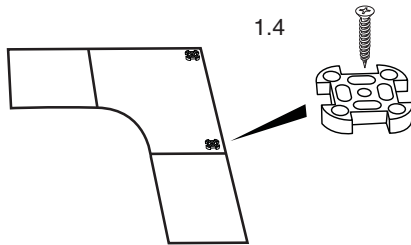
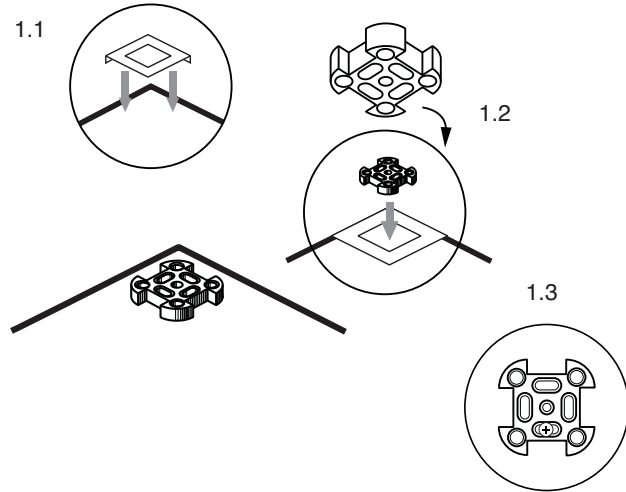

- 1.5 Temporarily position a panel between the two mounting plates. Adjust mounting plates so that a gap of approximately 1/16" or 2mm is between the panel and the plate.
- 1.6 Install all the remaining mounting plates that will be on your work surfaces following the above instructions. Remember when aligning the mounting plates use only the one short screw and do not tighten.

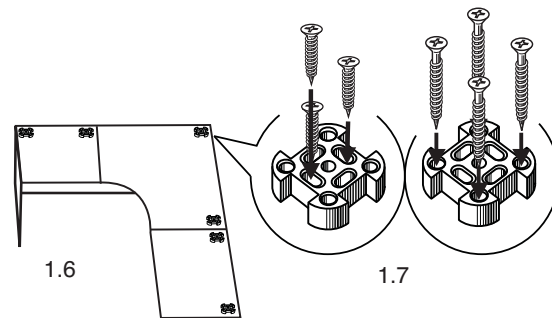
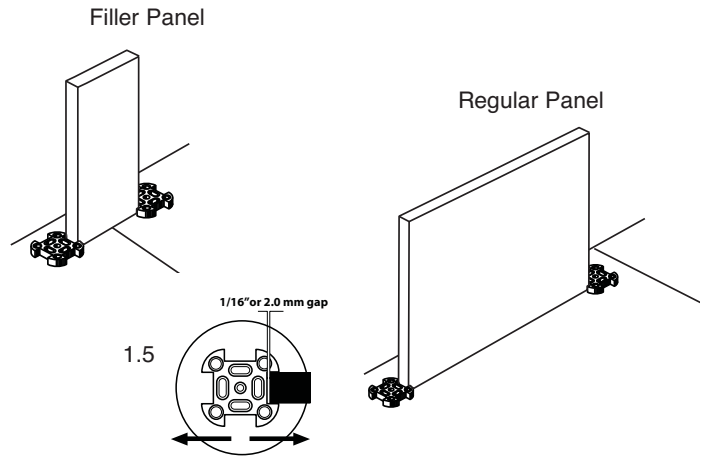

- 1.7 After all the mounting plates have been properly aligned, including having the panels temporarily positioned as per instruction 1.5, then install the remaining 3 - 1" screws in each mounting plate as shown, followed by the 4 - 1 1/4" in the four outside corners of the plate.



STEP 2. MOUNT DIVIDER POST

- 2.1 Place divider post over mounting plate.
- 2.2 Screw threaded rod through divider post and into mounting plate.
- 2.3 Place washer then nut on rod and finger tighten only.

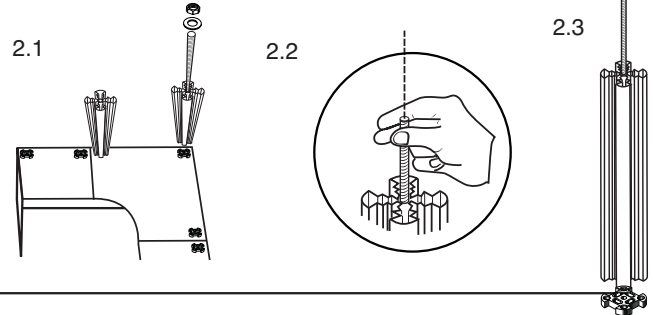

STEP 3. SLIDE PANELS INTO PLACE

- 3.1 Insert a 3/4" screw into threaded hole in each corner of the panel. Once all the way in, back out each screw 2 turns.
- 3.2 Slide panels into place, making sure that exposed screw head slides down appropriate channel on post.
- 3.3 If using glazed panel, in addition to the four screws, (not required on fabric panels) secure panel by inserting Neoprene strips between panel and post (Neoprene strips are provided with the panel).
- 3.4 Ensure cover strips on the post are properly placed. **Note. If using transaction tops, proceed to Step 4**
- 3.5 Tighten locking nut. Place caps on top of divider post,
- 3.6 If using 24" or 36" posts and 12" non clear panel, ensure spacer is installed on the bottom and follow Borders assembly instructions for stacking on panels. (Step 5.)

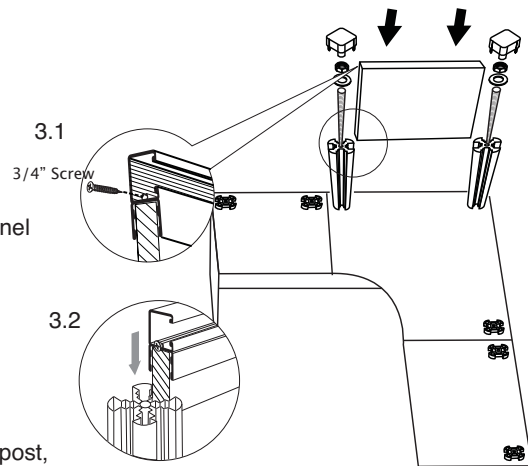

STEP 4. ATTACHING TRANSACTION TOPS

Note: All transaction tops come with necessary connecting hardware

- 4.1 Remove nut and washer. Slide connecting bracket onto threaded rod and divider post.
- 4.2 Fasten connecting bracket to divider post by tightening locking nut.
- 4.3 Align connecting brackets with recessed cut outs on underside of transaction tops.
- 4.4 Attach flat brackets to underside of adjoining transaction tops with 4 wood screws provided.

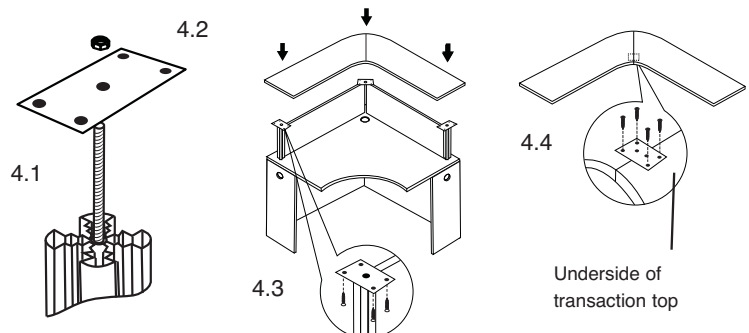



STEP 5. STACKING ON PANELS

Note: When using 2 stacked 12" panels, 24" high posts must be used.

- 5.1 Attach first level of panels as described in Step 3. Insert 2nd level of panels between 24" high posts in same fashion.
- 5.2 Tighten locking nut on the threaded rod and place caps on top of divider post.

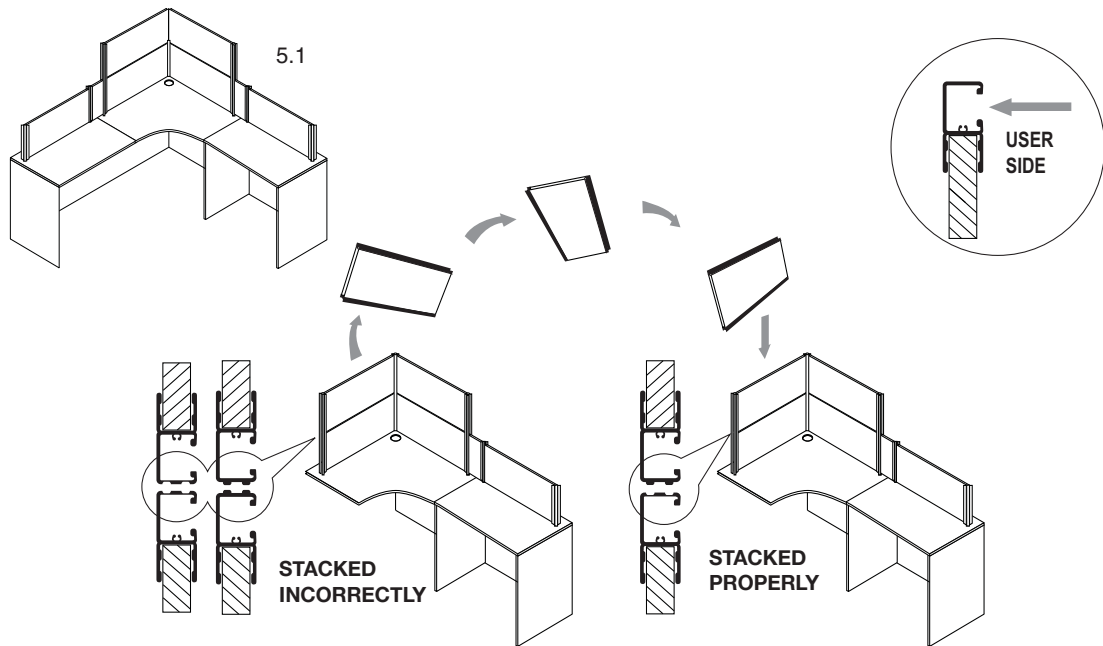

Please ensure panels are stacked properly - rails should fit in channels .

