

Before assembly, please remove all parts from the carton, verifying that you have the correct quantities, and read all the instructions.

****Please Note: When attaching the metal legs to the laminated tops, installed D-Nut holes are to be used as a guideline only for installation, wood screws need to be attached as well, whenever they are provided. Not all of the provided holes on these metal legs will line up with the inserts on the laminated tops. The provided wood screw may also need to be used****

INSTRUCTIONS:

IN THE CARTON:

A. Main Desk Setup

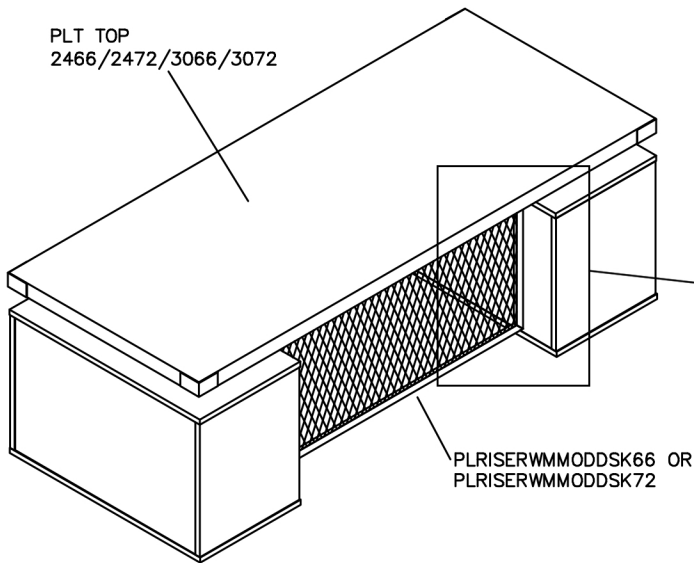

Parts List

1		Bolts M6 X 12mm	4 pcs
---	---	--------------------	-------

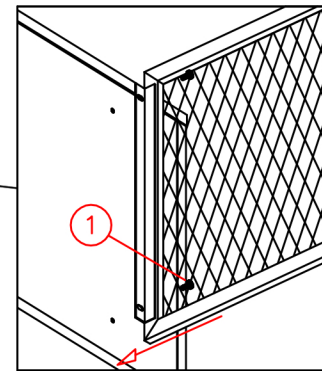

Following the metal inserts on the cabinets, attach riser wire mesh modesty panel to the cabinets with using bolts M6 x 12mm (part 1).

The same step is applicable to all the riser wire mesh modesty panel.

B. Return Setup

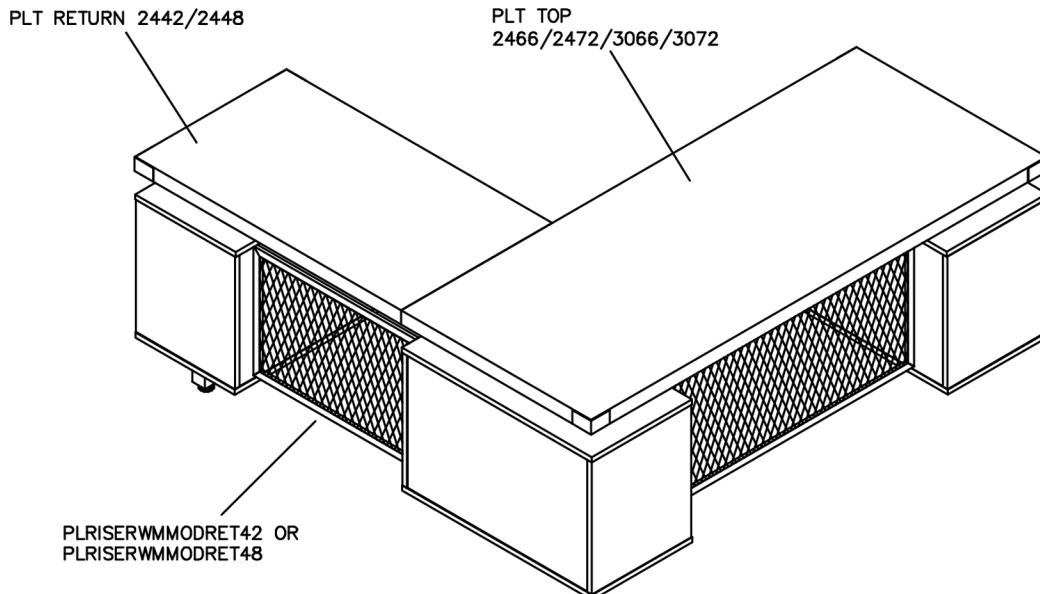

INSTRUCTIONS:



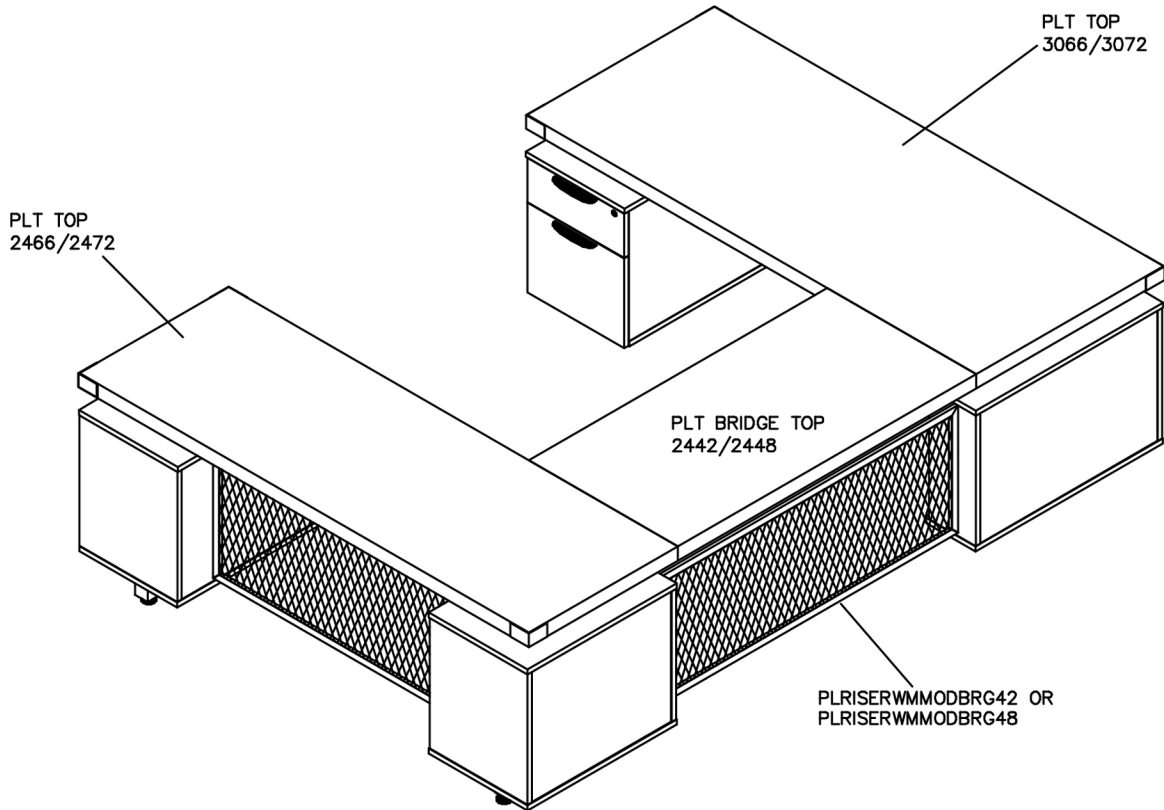







C. U-Shape Bridge Setup

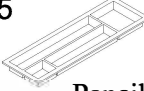

⚠ ATTENTION ⚠

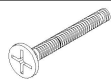
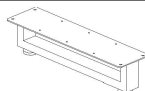
Do not tighten any screws or bolts until the unit is completely assembled.
Ensure all bolts and screws are tightened before using the table, check bolts and screws every 6 months.
If any parts are missing, broken, damaged or worn, stop use of product until repairs have been made using factory authorized parts.
Failure to follow these warnings may result in injury.

Before assembly, please remove all parts from the carton, verifying you have the correct quantities, and read all the instructions.
****Please Note: When attaching the metal legs to the laminated tops, installed D-nut holes are to be used as a guideline only for installation, wood screws need to be attached as well, whenever they are provided. Not all of the provided holes on these metal legs will line up with the inserts on the laminated tops. The provided wood screw may also need to be used****

1  Aluminium Flat Handle 2 Pcs	2  Screw M4 x 25mm 4 Pcs	3  File Clip 2 Pcs	4  Aluminium Bar 1 Pcs	5  Pencil Tray 1 Pcs	6  Bolt M6x20mm(Black) 6 Pcs
7  CSK screw M3.5 X 20 MM 14 Pcs	8  Bolt M6x40mm(Silver) 2 Pcs	9  U-Shape Riser 1 Pcs	10  Single Riser 2 Pcs	11  Sticker Cap 2 Pcs	12  Metal Washer 2 Pcs

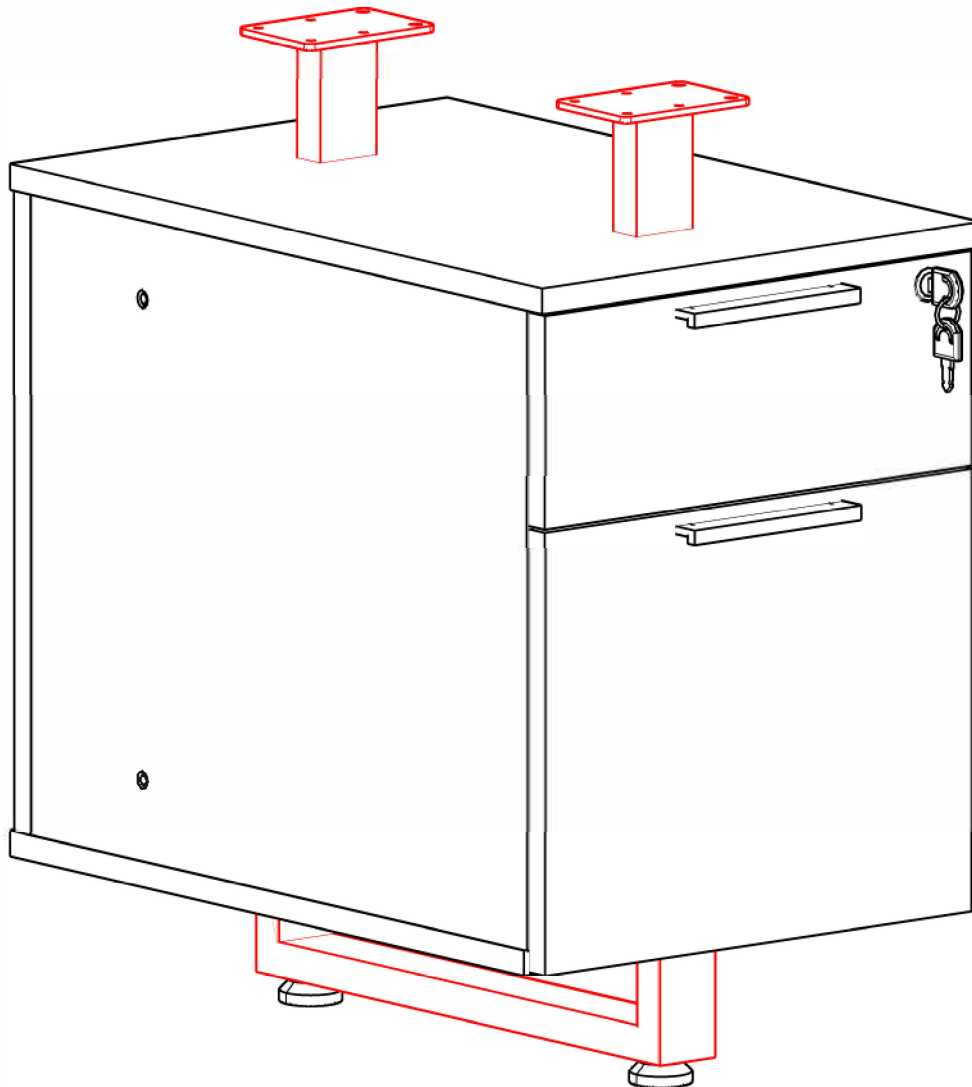

IMPORTANT!

- Place all wooden parts on a clean and smooth surface such as a rug or carpet to avoid the parts from being scratched.
- Check that you have all the parts and hardware.
- Remove all wrapping materials, including staples & packing straps before you start to assemble
- Do not tighten any screws or bolts until the unit is completely assembled.
- Keep all hardware parts out of reach of children.

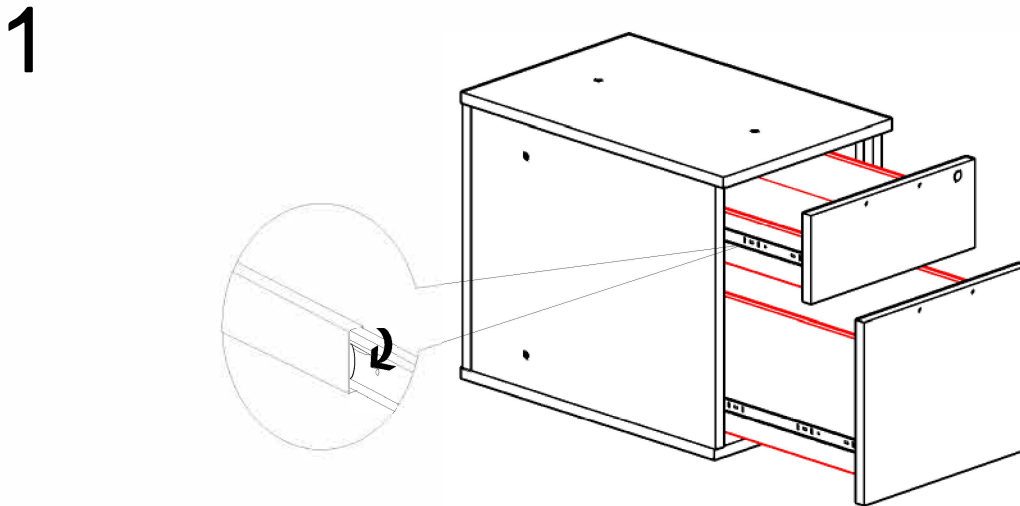

Remove drawer from pedestal. Fully open drawer. Where first slide meets second slide there is a small clip. Pull the clip on the left hand slide up, push the clip on the right hand slide down. Pull drawer out.

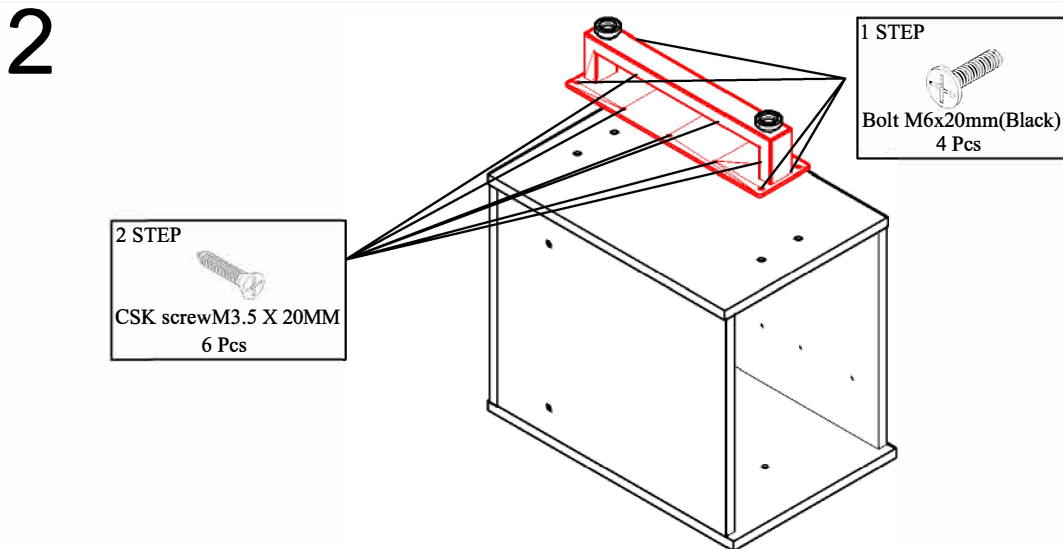

U-Shape Riser (metal leg) are placed at the bottom panel. Use the existing d-nut and pre-drilled hole as the guide line.

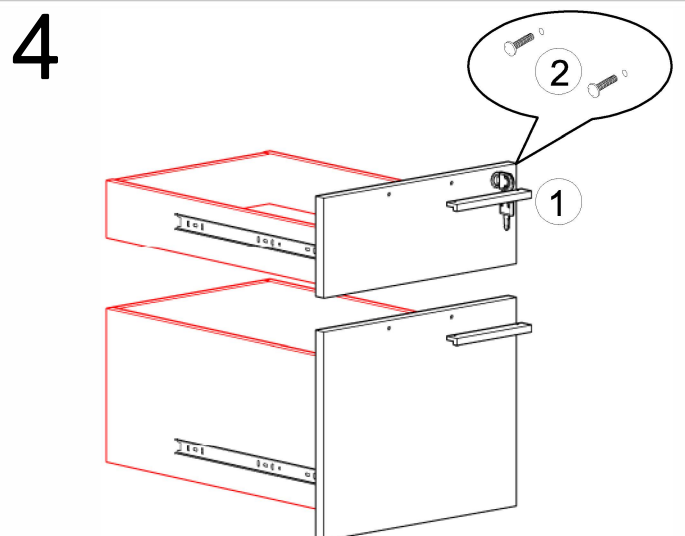
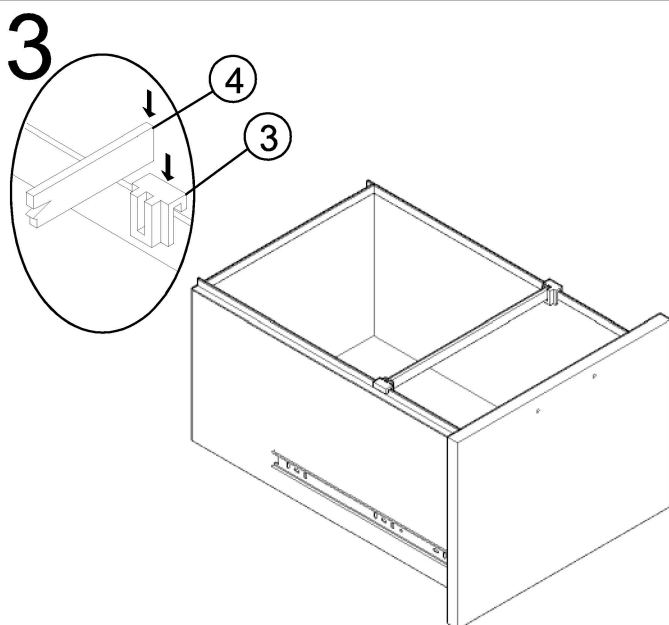

Attach Handle(1) to the drawer front and screw it from behind drawer front by using handle screw(2)

FOR PLT TOP
-PLT 3072 / 3066

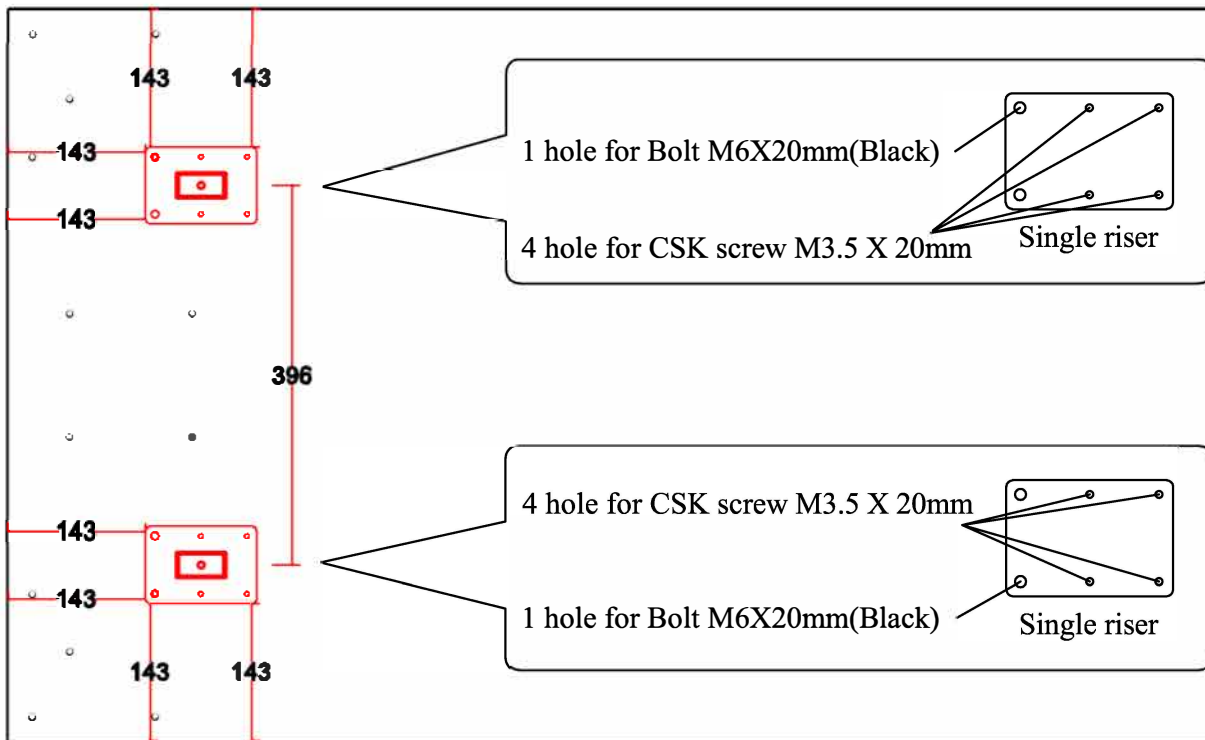
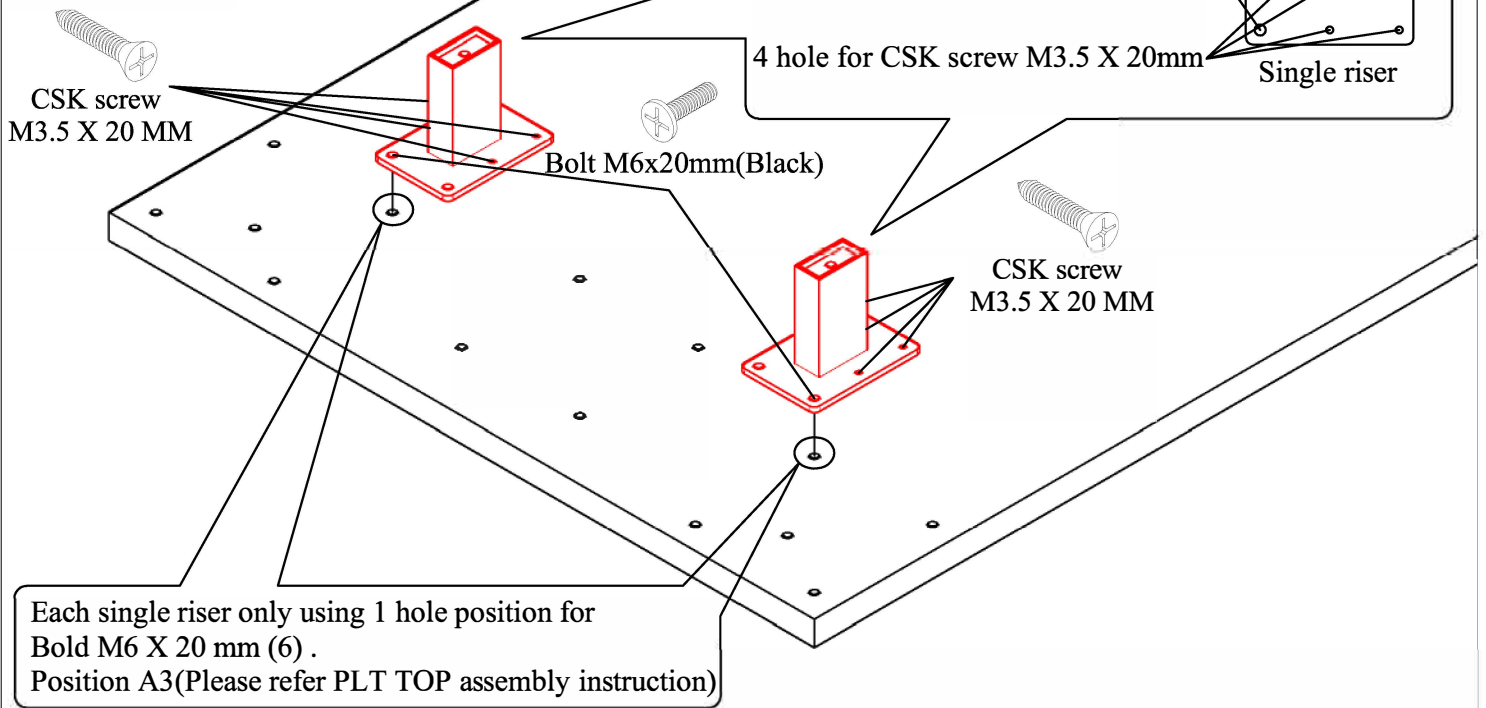

Please check the position of the single riser. 143 mm from each side and 396mm between the single riser leg(Center point). Repeat the step at the other side. Then used the csk screw M3.5 x 20mm at remaining hole.

FOR PLT TOP
-PLT 2472 / 2466 / 2442

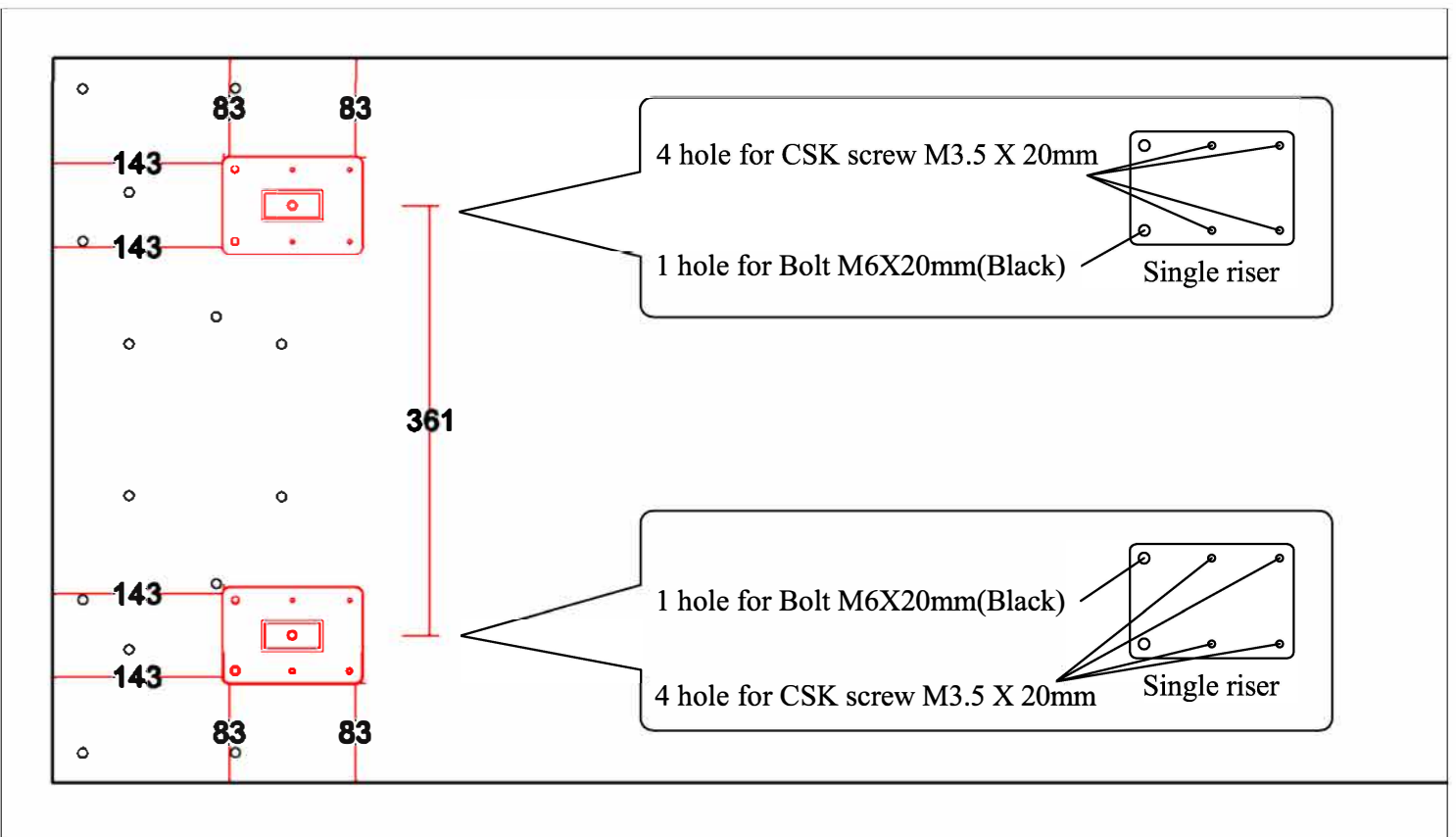
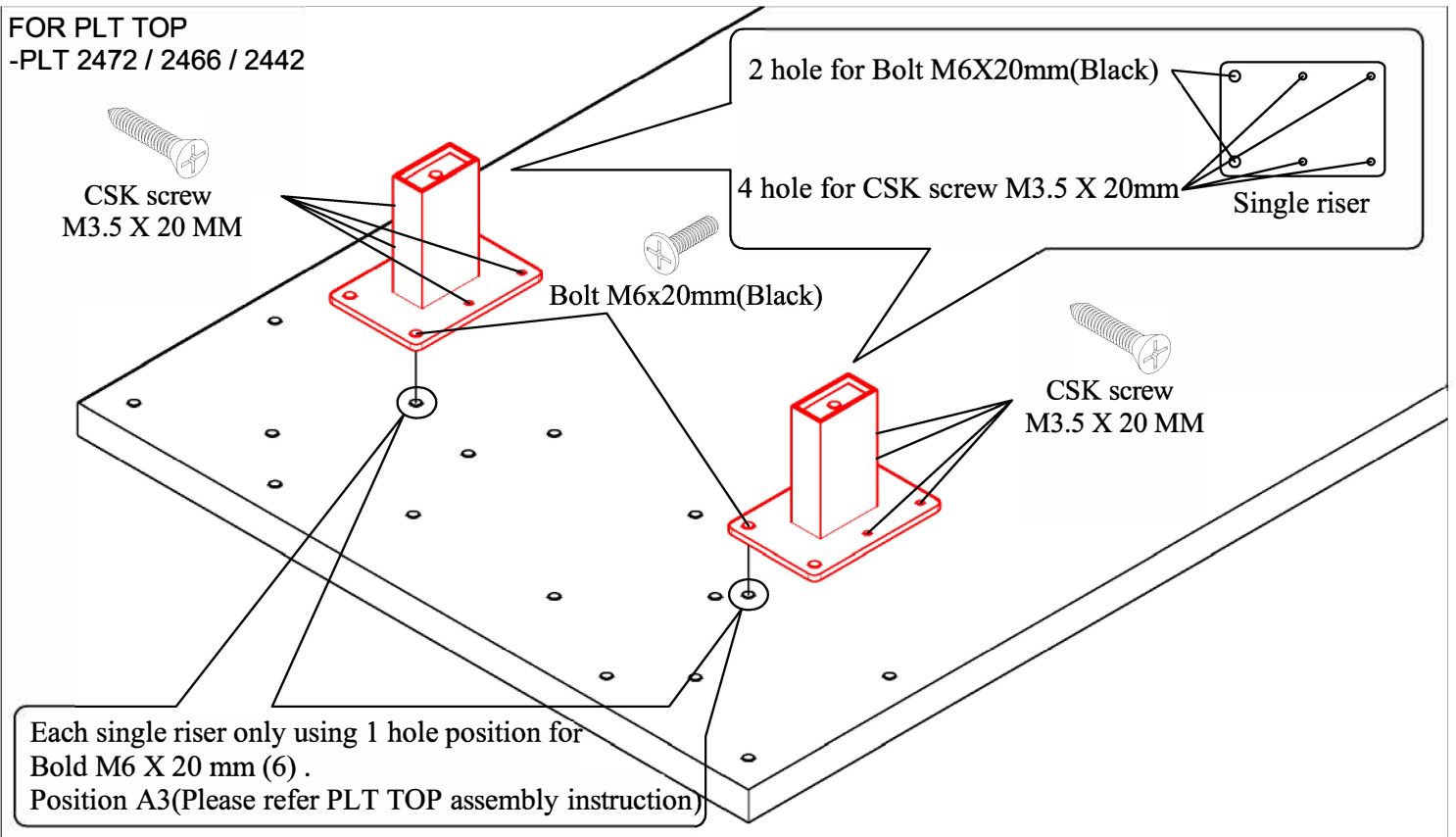

Please check the position of the single riser. 143 mm from side and 83 mm front / back. 361 mm between the single riser leg(Center point). Repeat the step at the other side. Then used the csk screw M3.5 x 20mm at remaining hole.

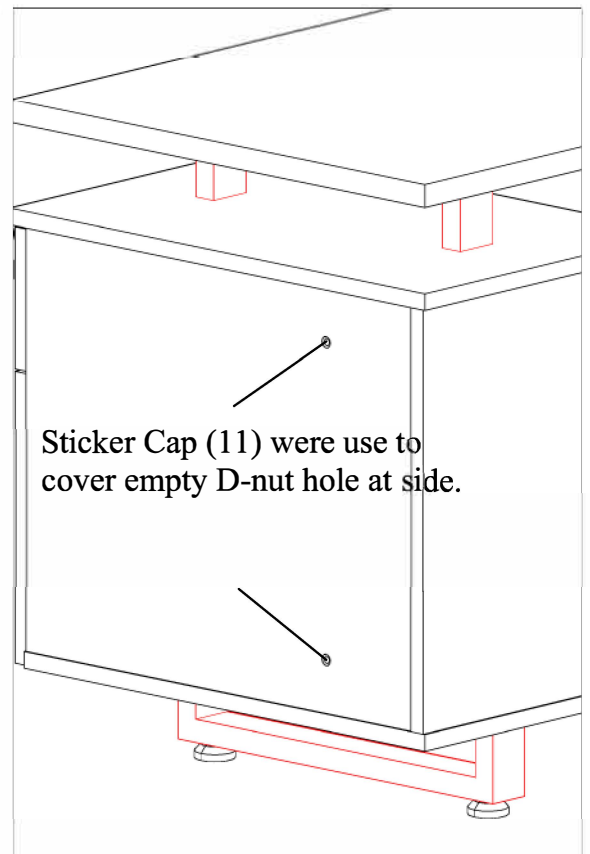
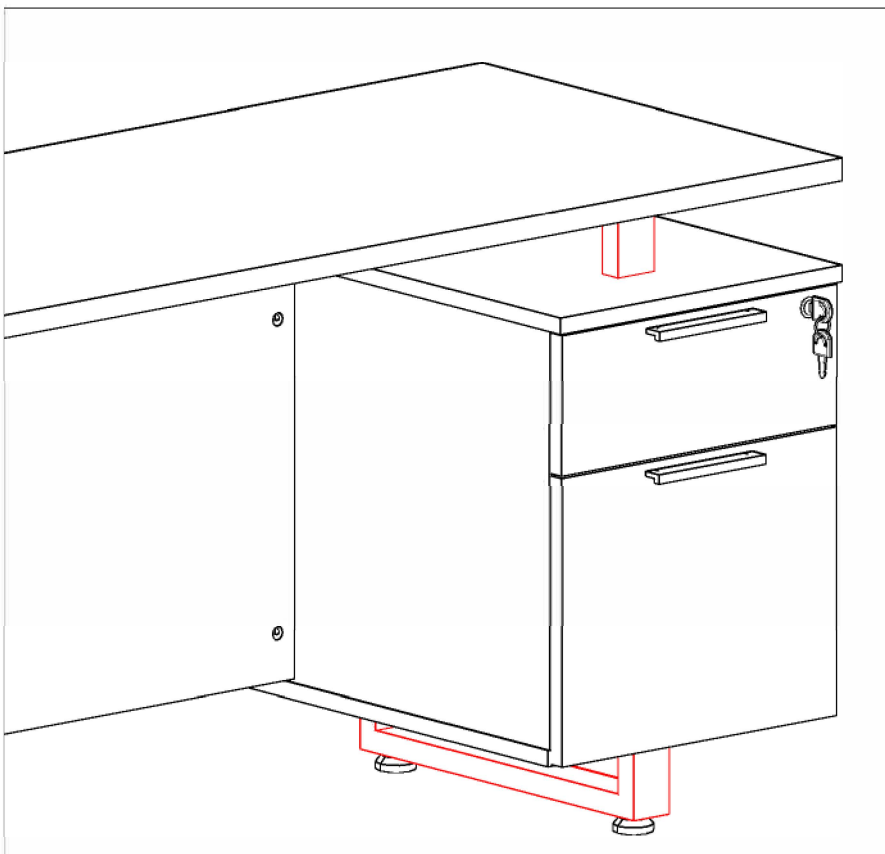
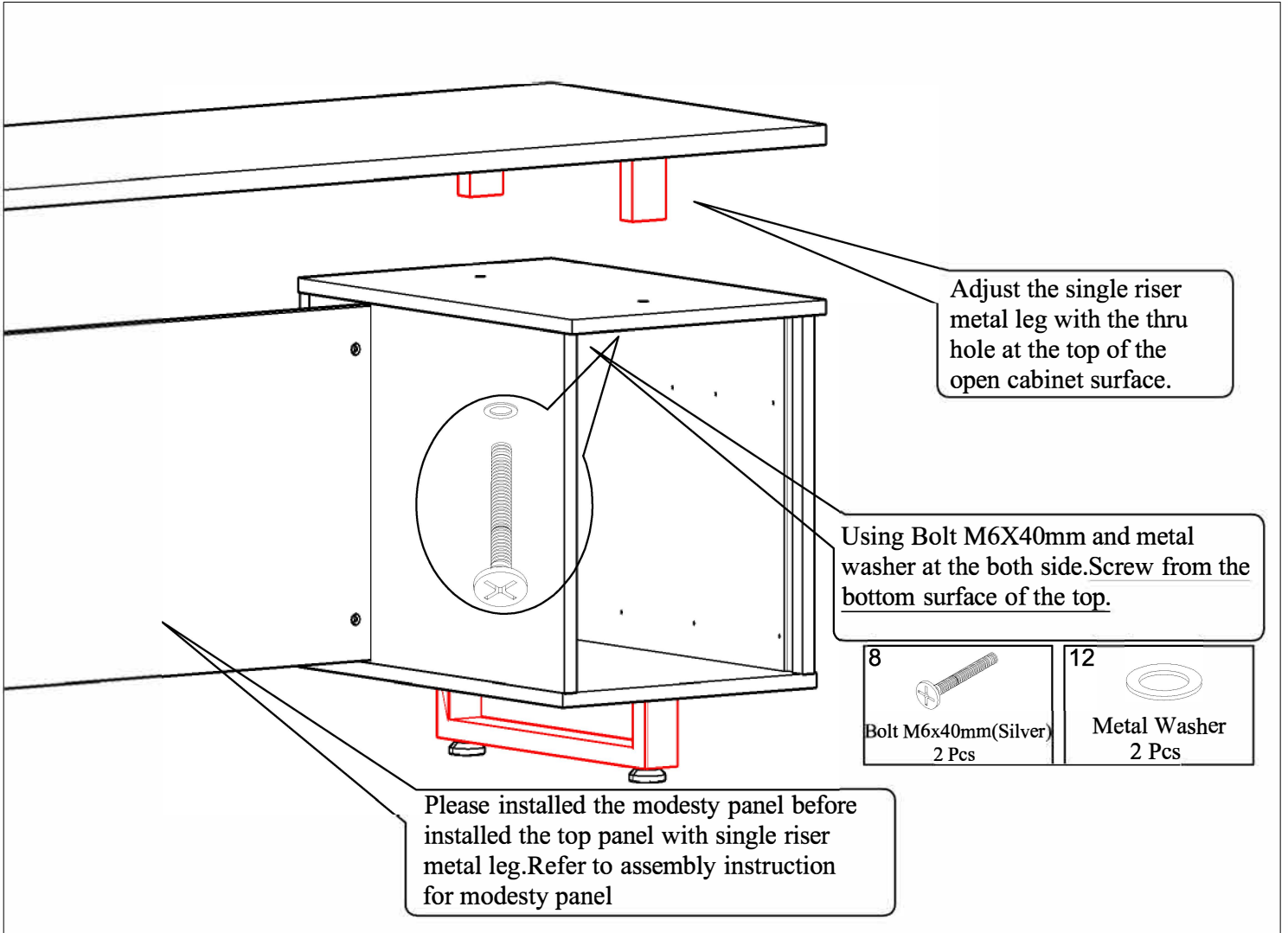

Before assembly, please remove all parts from the carton, verifying you have the correct quantities, and read all the instructions.
****Please Note:** When attaching the metal legs to the laminated tops, installed D-nut holes are to be used as a guideline only for installation, wood screws need to be attached as well, whenever they are provided. Not all of the provided holes on these metal legs will line up with the inserts on the laminated tops. The provided wood screw may also need to be used**

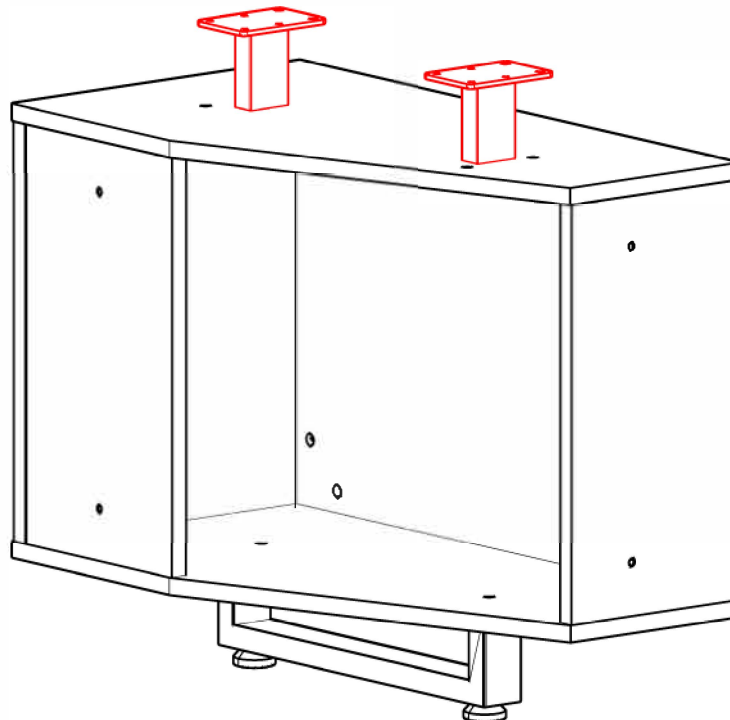
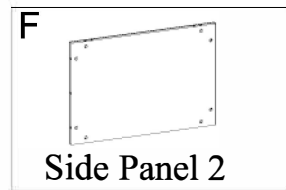
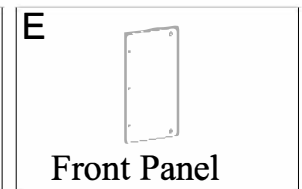
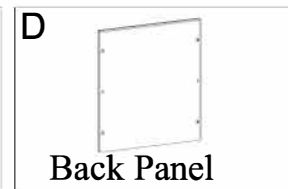
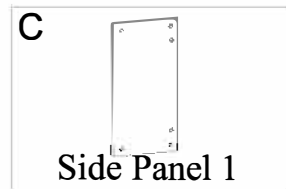
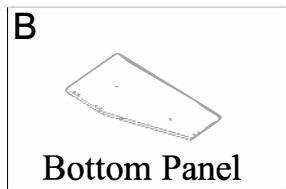
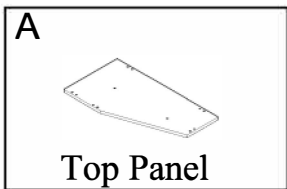
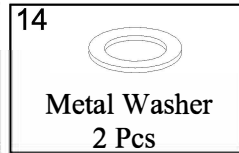
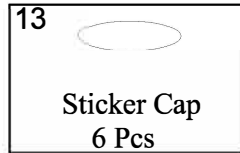
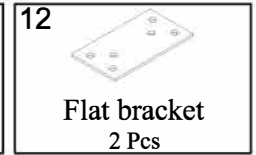
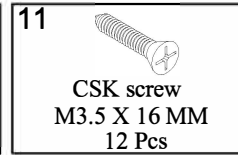
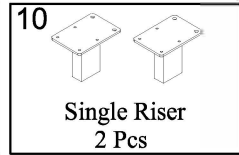
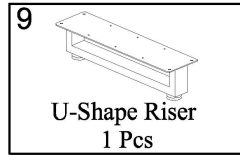
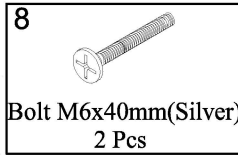
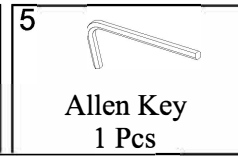
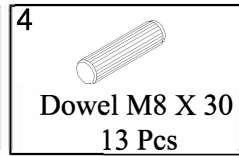
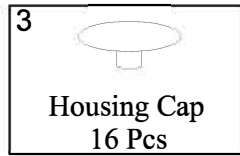
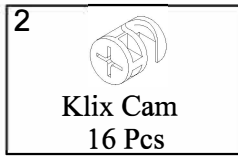

IMPORTANT!

- Place all wooden parts on a clean and smooth surface such as a rug or carpet to avoid the parts from being scratched.
- Check that you have all the parts and hardware.
- Remove all wrapping materials, including staples & packing straps before you start to assemble
- Do not tighten any screws or bolts until the unit is completely assembled.
- Keep all hardware parts out of reach of children.

KLIX CAM AND CAM LOCK INSTRUCTION

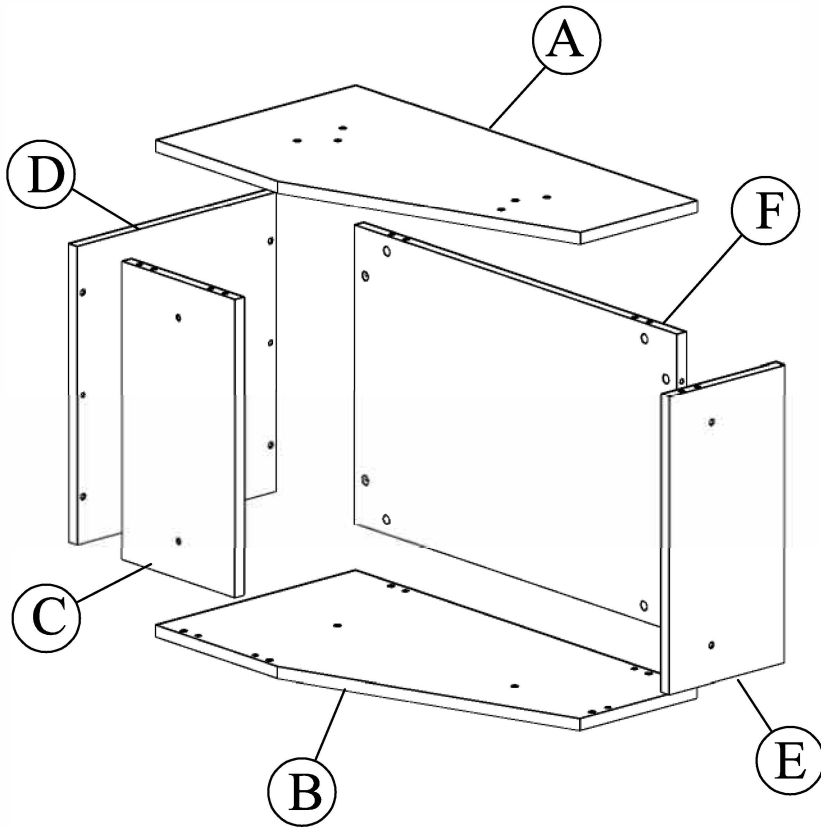

Attach all panel according to the image . Please ensure all the panel are correct:-

- (A) Top
- (B) Bottom
- (C) Side panel 1
- (D) Back panel
- (E) Front panel
- (F) Side panel 2

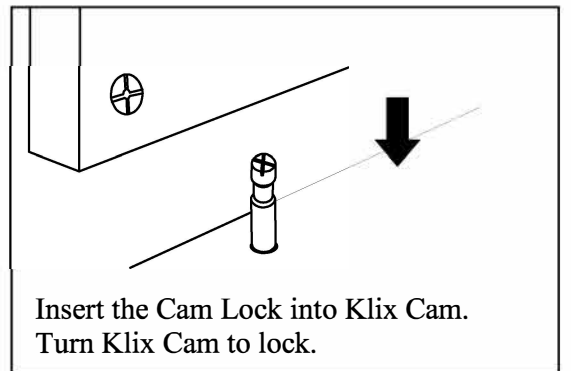
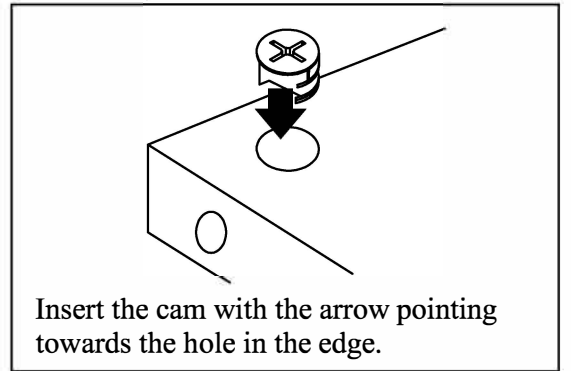
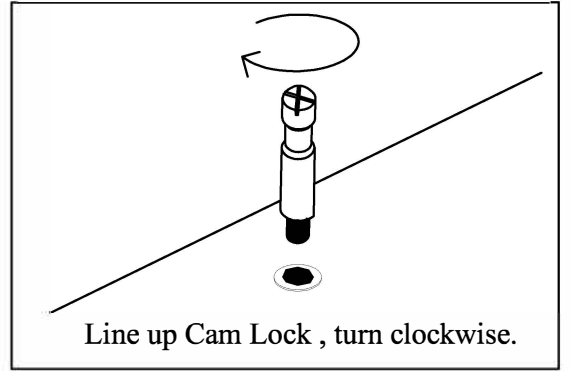

DOWEL INSTRUCTION

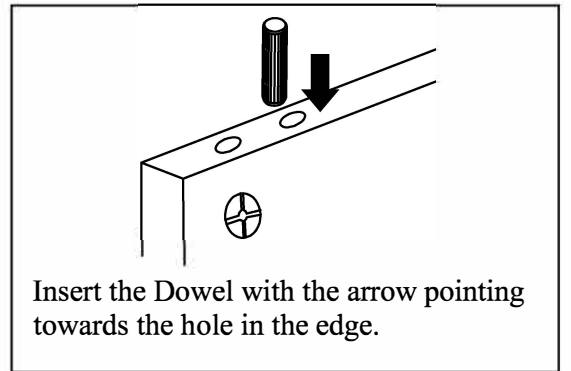

HOUSING CAP INSTRUCTION

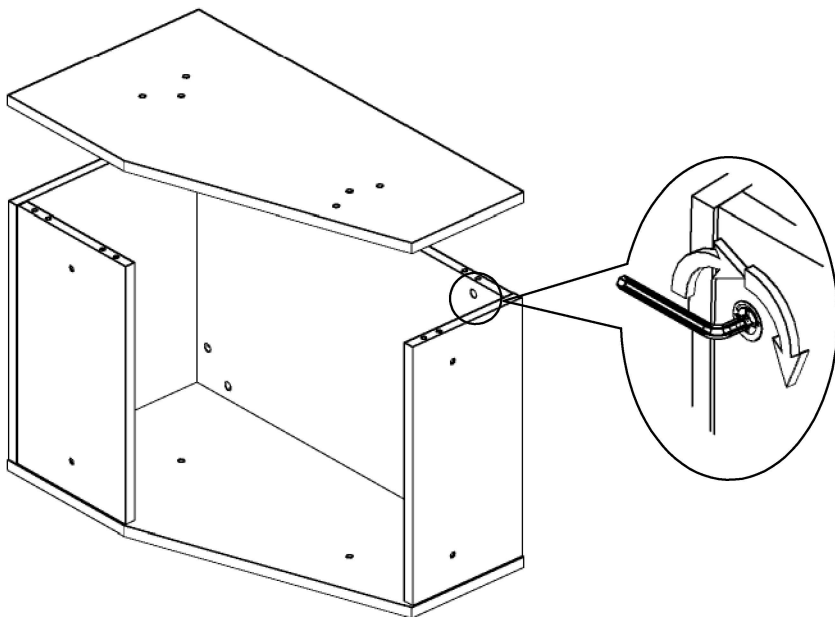
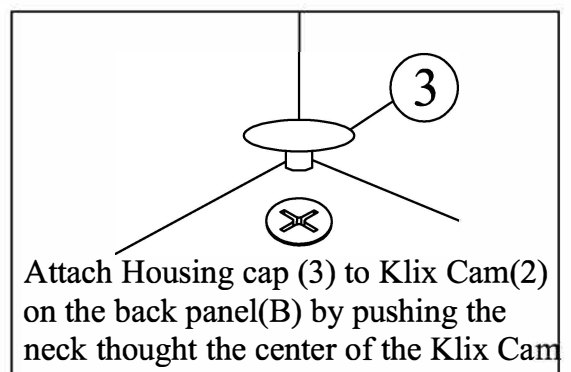

Use sticker cap (13) , to cover the D-Nut hole at top surface

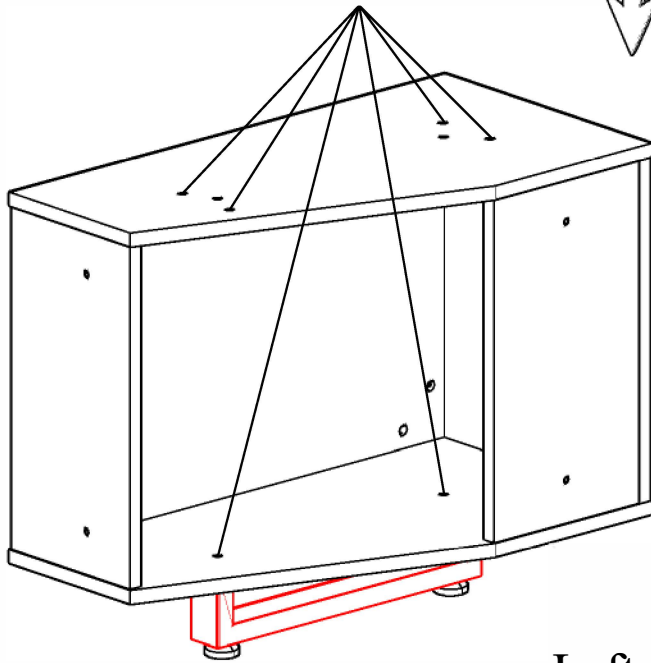

2 STEP
CSK screw M3.5 X 20 MM
6 Pcs

1 STEP
Bolt M6x20mm(Black)
4 Pcs

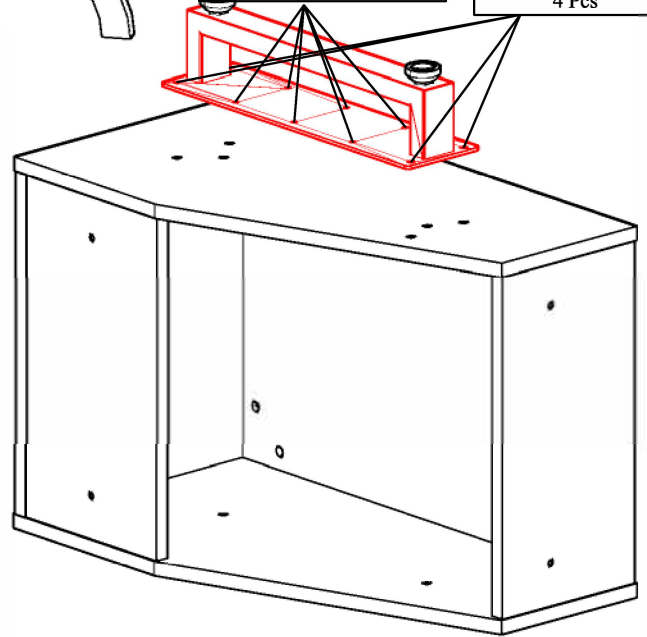

Left side position.

1 STEP
Bolt M6x20mm(Black)
4 Pcs

2 STEP
CSK screw M3.5 X 20 MM
6 Pcs

Use sticker cap (13) , to cover the D-Nut hole at top surface

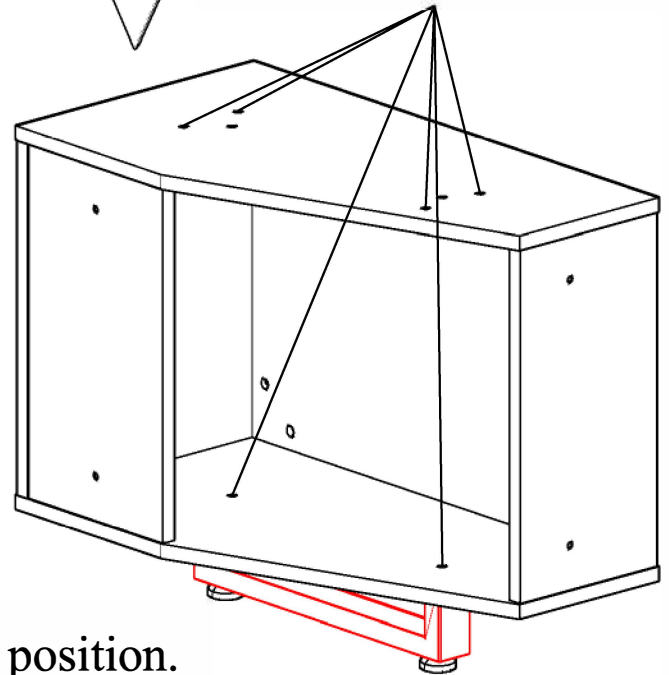
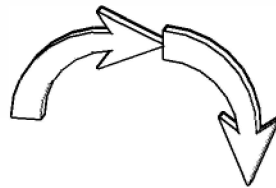
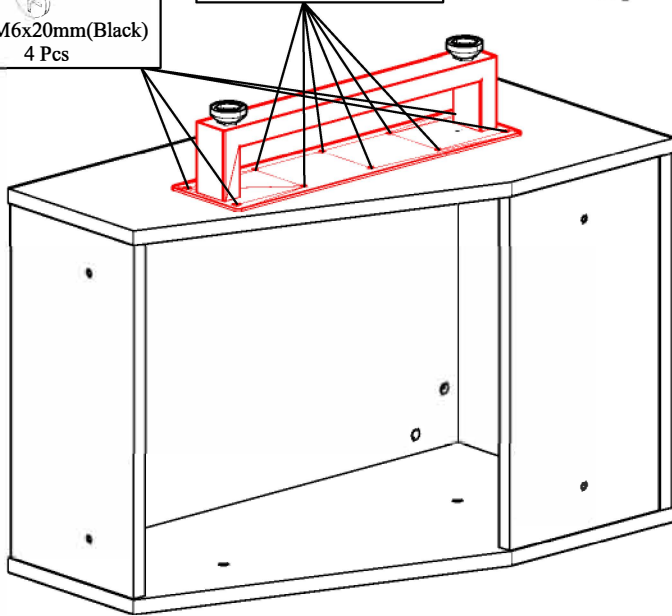

Right side position.

Design for the 24" open type pedestal & 30" open type pedestal can installed either left side or the right side.

FOR PLT TOP
-PLT 3072 / 3066

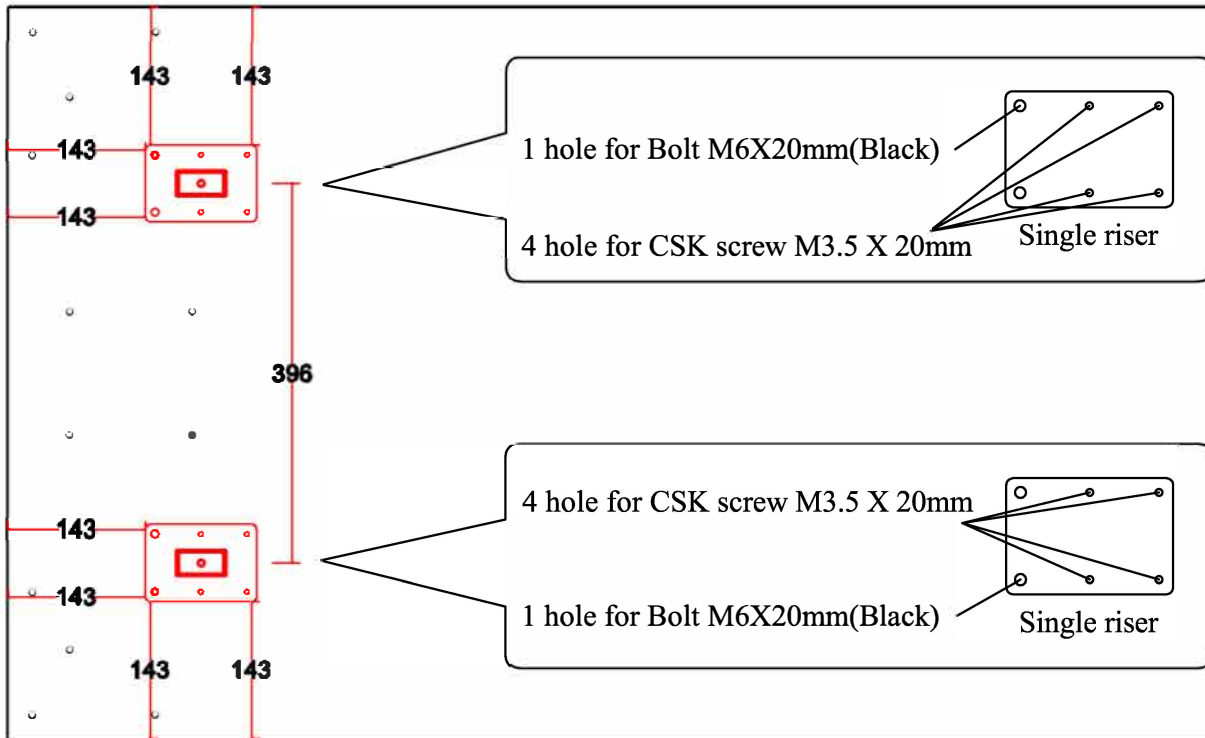
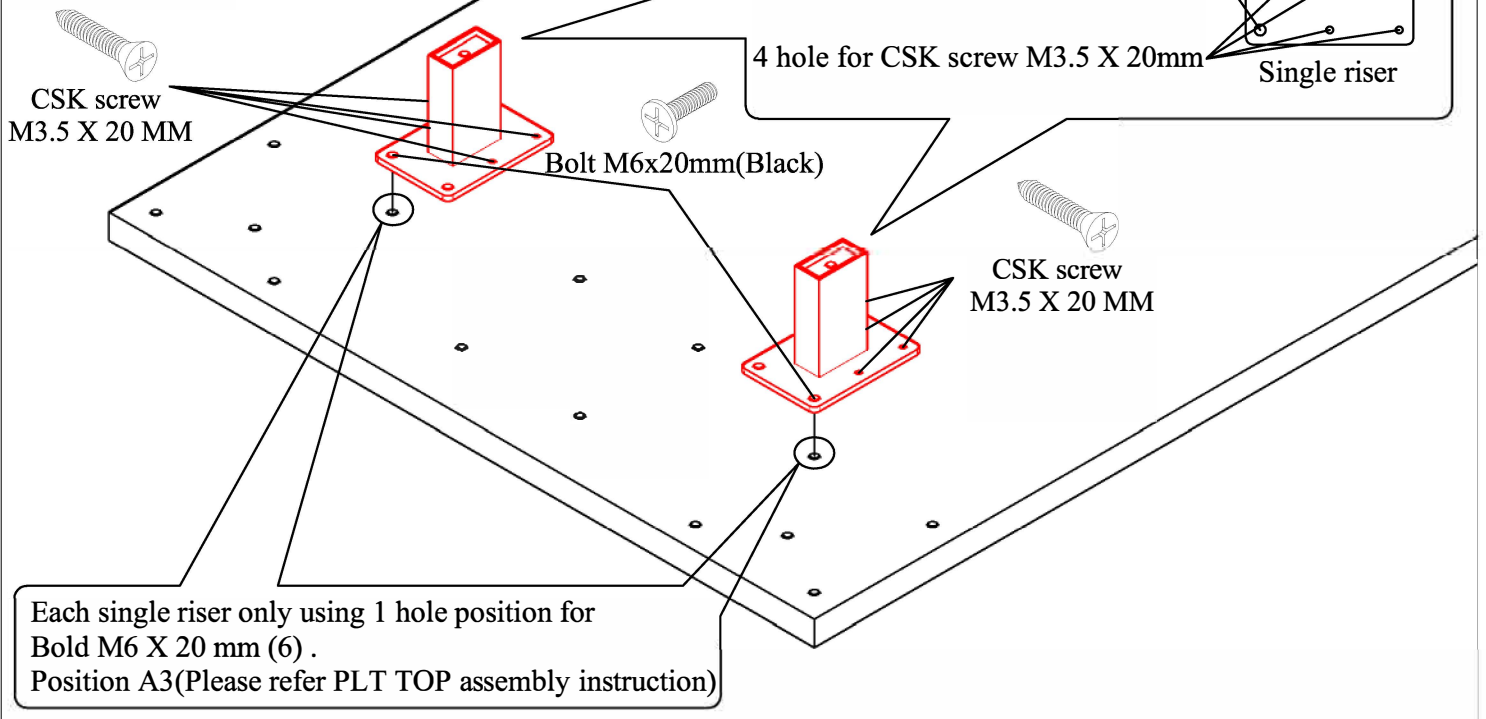

Please check the position of the single riser. 143 mm from each side and 396mm between the single riser leg(Center point). Repeat the step at the other side. Then used the csk screw M3.5 x 20mm at remaining hole.

FOR PLT TOP
-PLT 2472 / 2466 / 2442

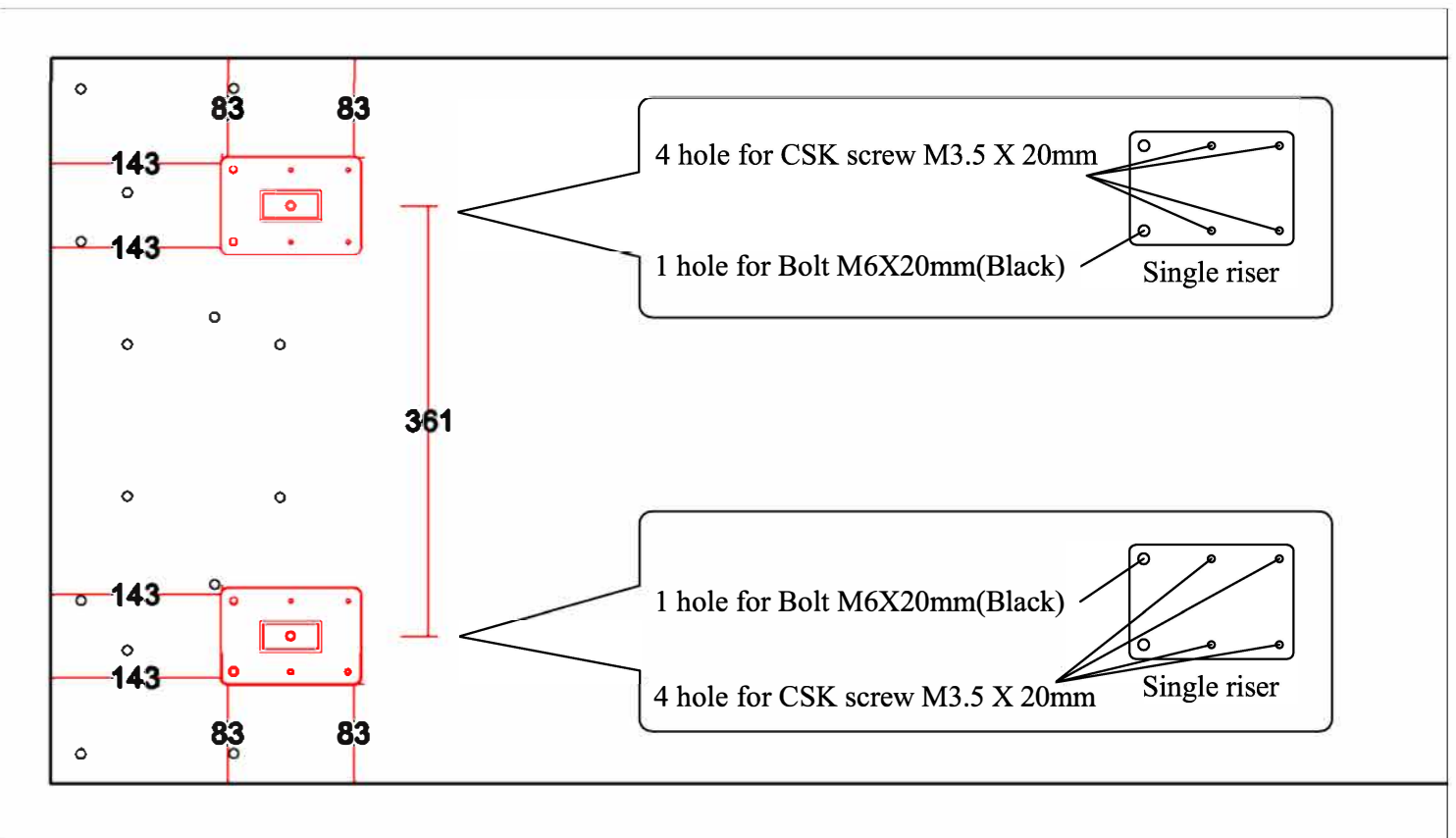
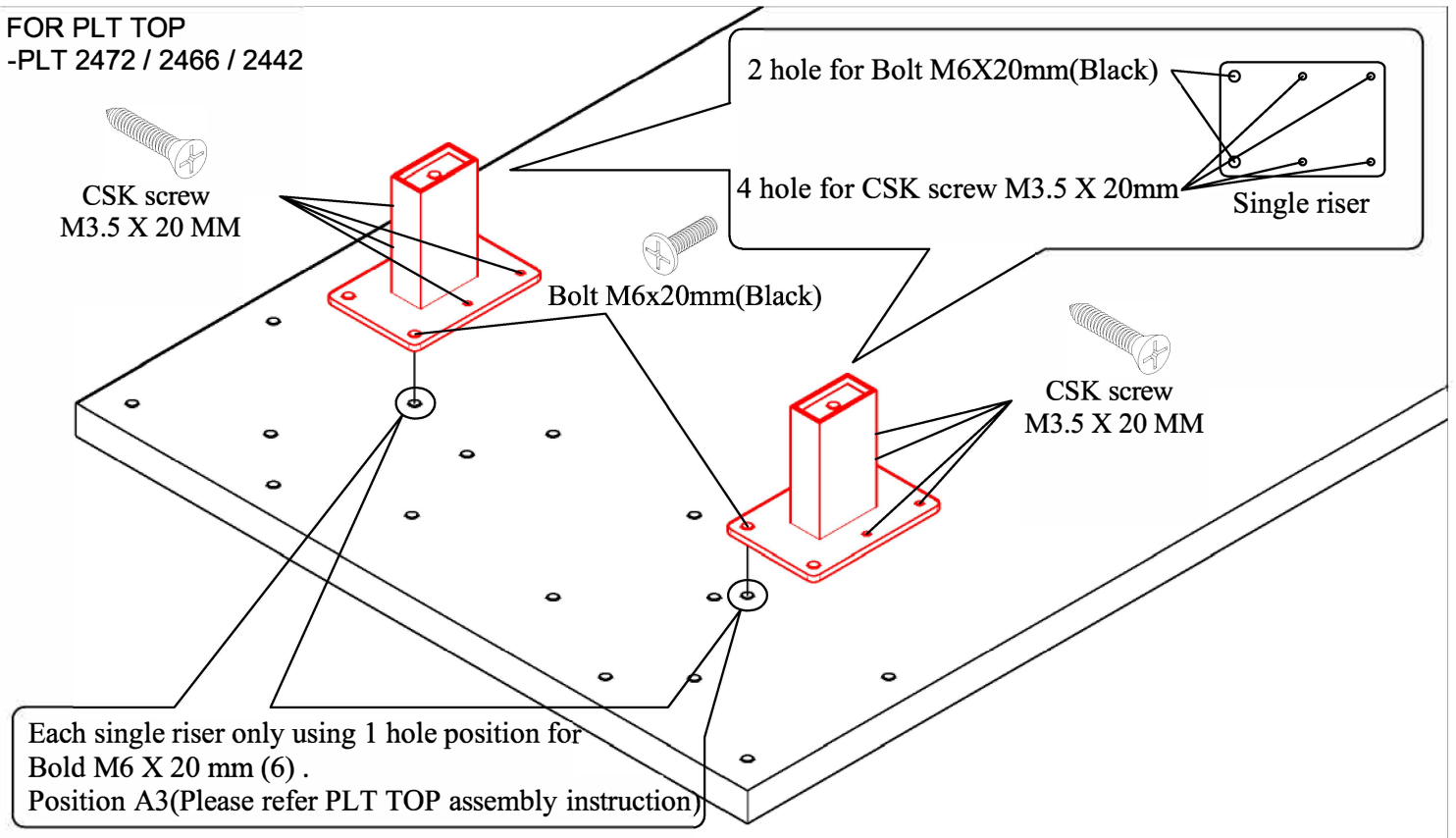

Please check the position of the single riser. 143 mm from side and 83 mm front / back. 361 mm between the single riser leg(Center point). Repeat the step at the other side. Then used the csk screw M3.5 x 20mm at remaining hole.

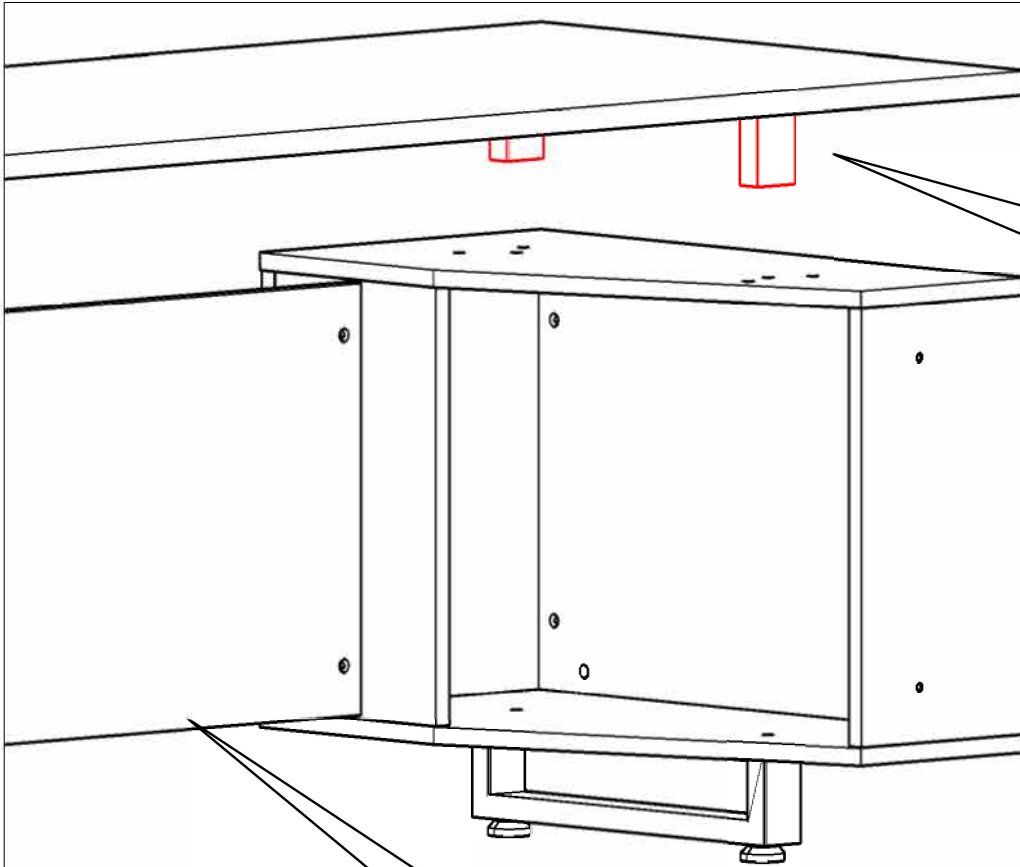

Adjust the single riser metal leg with the thru hole at the top of the open cabinet surface.

Please installed the modesty panel before installed the top panel with single riser metal leg. Refer to assembly instruction for modesty panel

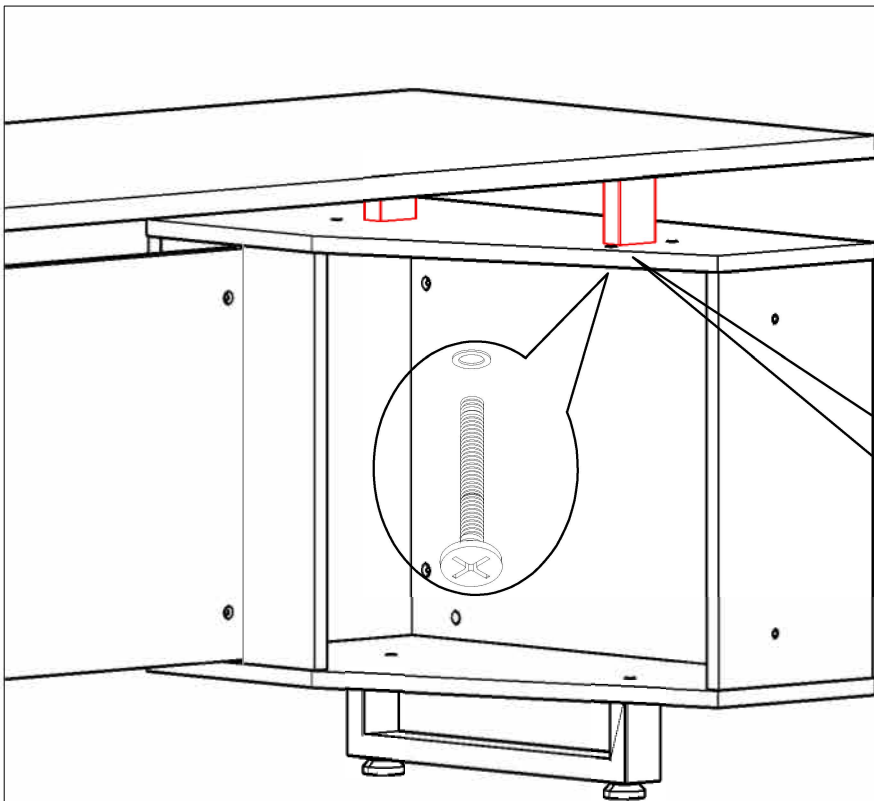

Using Bolt M6X40mm and metal washer at the both side. Screw from the bottom surface of the top.

8
Bolt M6x40mm(Silver)
2 Pcs

14
Metal Washer
2 Pcs

Before assembly, please remove all parts from the carton, verifying you have the correct quantities, and read all the instructions.
****Please Note:** When attaching the metal legs to the laminated tops, installed D-nut holes are to be used as a guideline only for installation, wood screws need to be attached as well, whenever they are provided. Not all of the provided holes on these metal legs will line up with the inserts on the laminated tops. The provided wood screw may also need to be used**

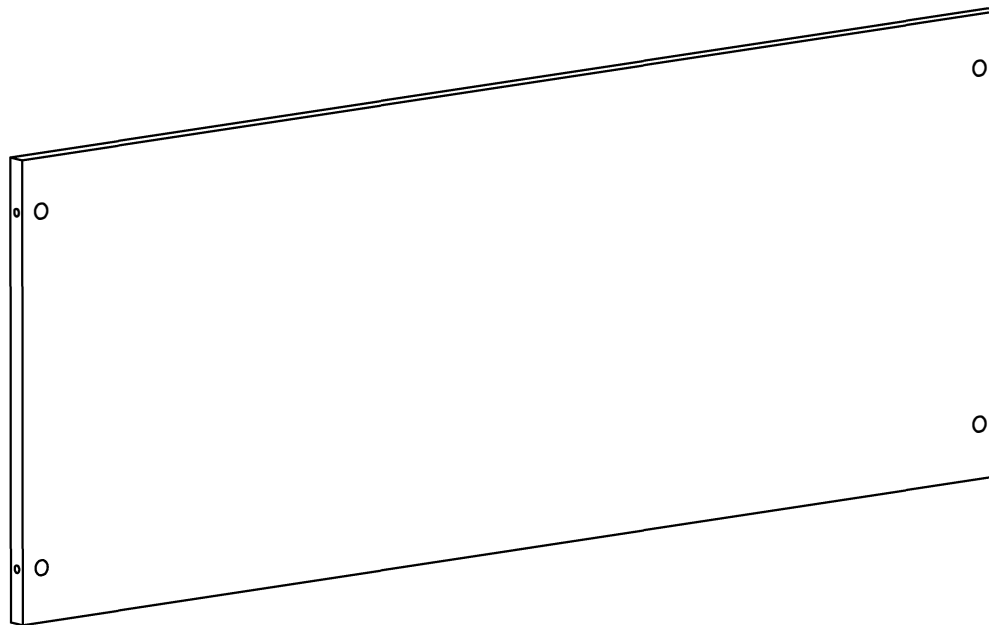
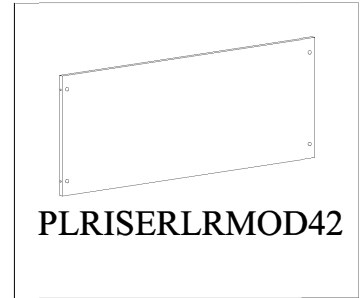
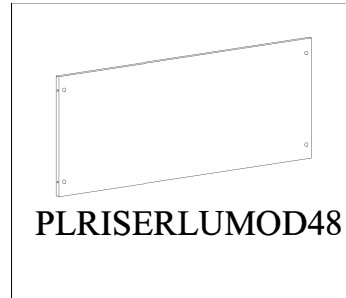
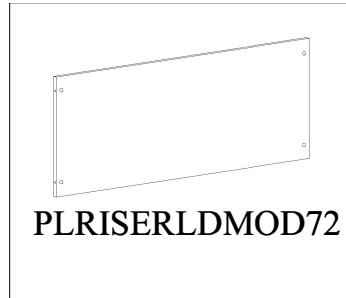
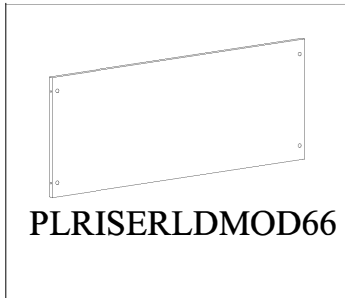
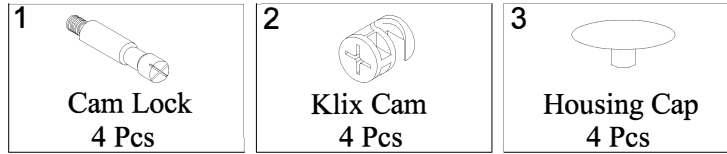

IMPORTANT!

- Place all wooden parts on a clean and smooth surface such as a rug or carpet to avoid the parts from being scratched.
- Check that you have all the parts and hardware.
- Remove all wrapping materials, including staples & packing straps before you start to assemble
- Do not tighten any screws or bolts until the unit is completely assembled.
- Keep all hardware parts out of reach of children.

1-MAIN DESK SETUP

PLT TOP
2466 / 2472 / 3066 / 3072

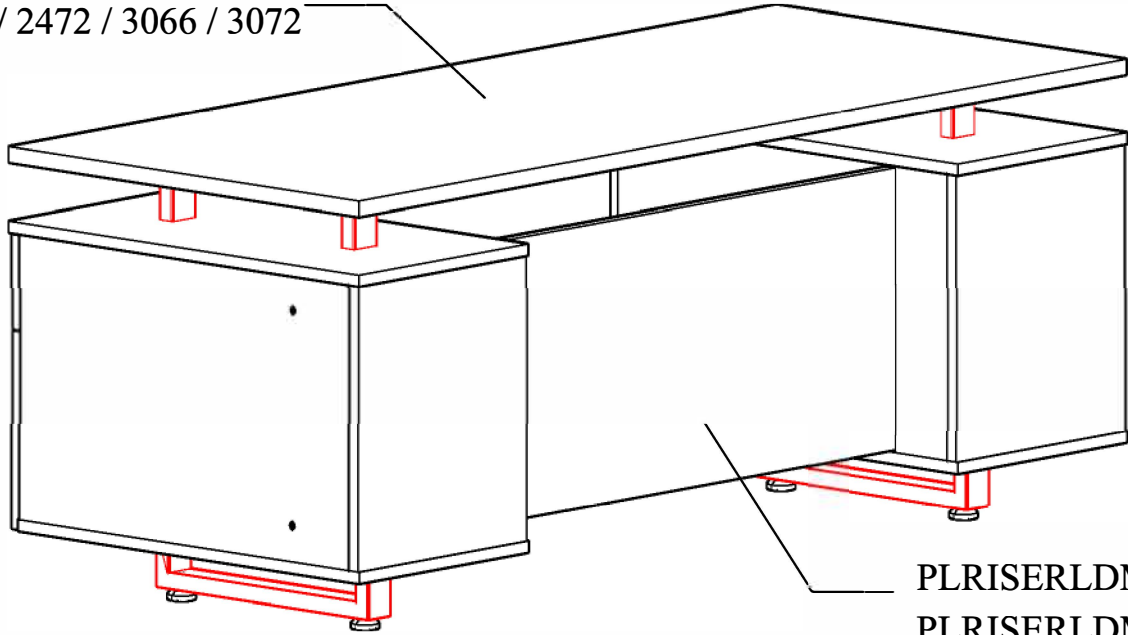

PLRISERLDMOD66
PLRISERLDMOD72

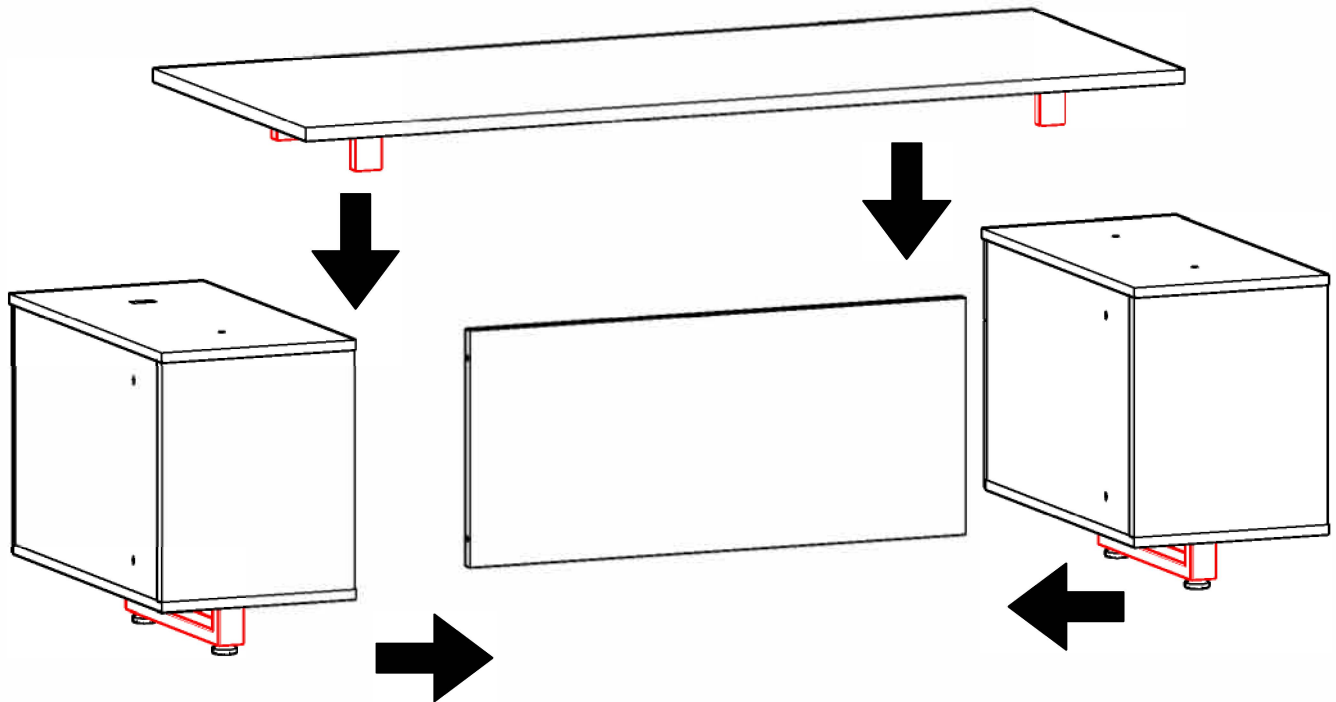

2-RETURN SETUP

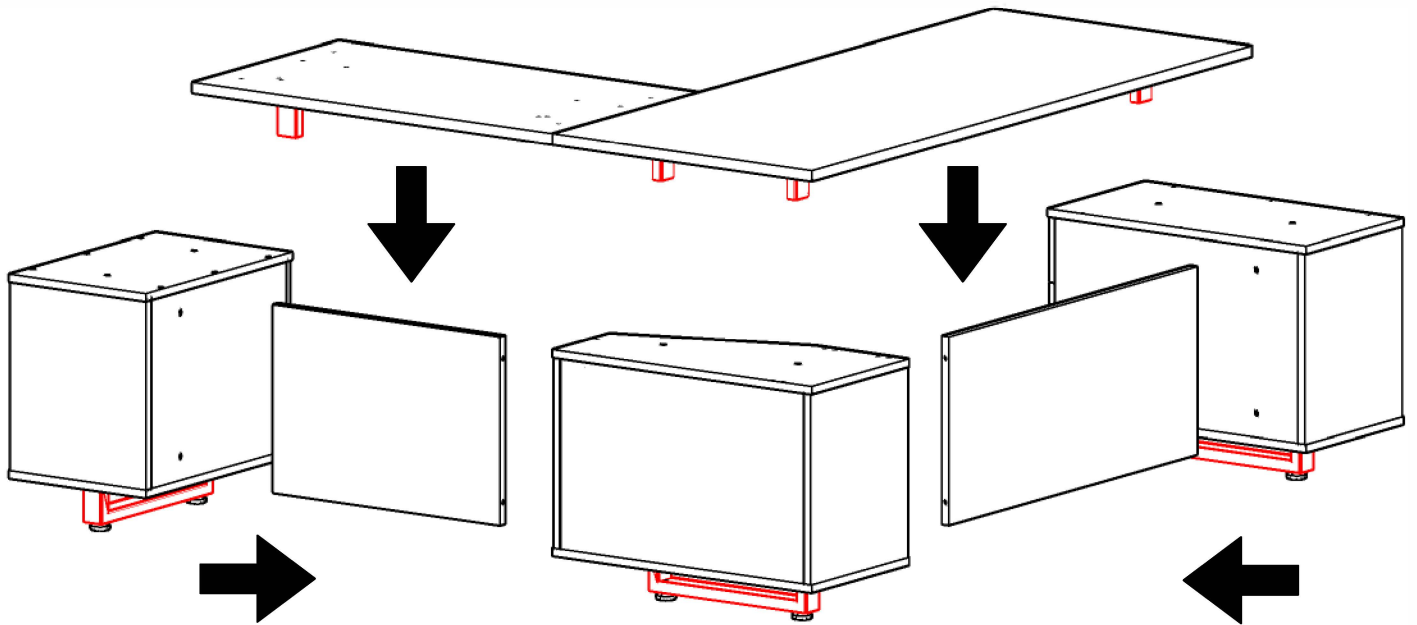
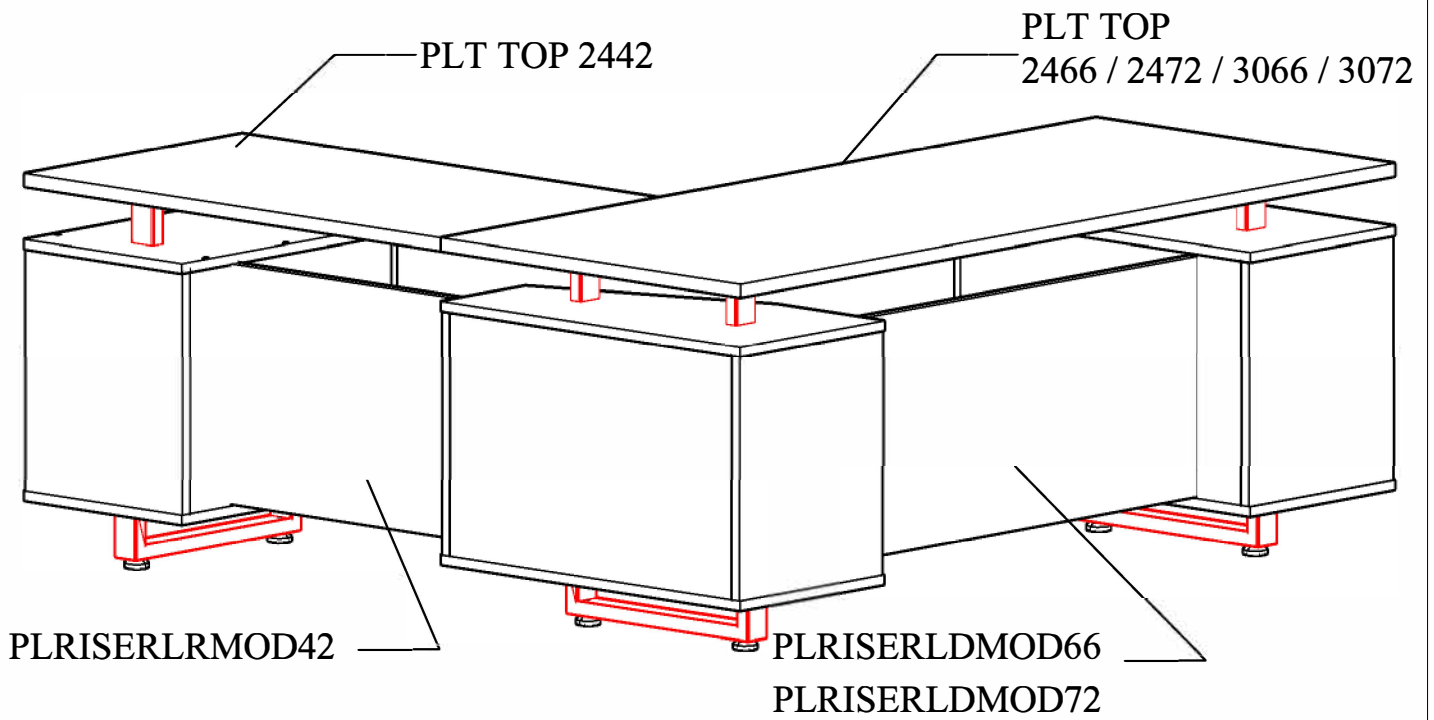

3-U-SHAPE BRIDGE SETUP

